

Miniature Bodywork
Flexible Operation

TELEHANDLER

T5010



ANK
汉科智能

TELEHANDLER T5010

Capacities 容量		T5010
Max. capacity 最大容量		5000 kg
Max. lifting height 最大举升高度		9.8 m
Max. outreach 最大伸出长度		4.5m
Weight and dimensions 重量和尺寸		
Overall length to carriage 总长度 (不含拖叉)	l11	6.4 m
Length to face of forks 总长度 (含拖叉)	l1	7.62 m
Overall width 总宽度	b1	2.4m
Overall height 总高度	h17	2.55 m
Wheelbase 轴距	y	3.15 m
Ground clearance 离地间隙	m4	0.38 m
Overall cab width 驾驶室总宽度	b4	0.84 m
Tilt-up angle 向上倾斜度	a4	12 °
Tilt-down angle 向下倾斜度	a5	114 °
External turning radius(over tyres) 外部转弯半径 (含轮胎)		4.1 m
Unladen weight(with fork) 空车重量 (含拖叉)		12800 kg
Tires type 轮胎类型		Semi-solid
Standard tires 标准轮胎		16/70 -24
Forks length/ width/ section 拖叉长度/宽度/截面	l / e / s	1220 mm x 125 mm / 50 mm
Performances 性能		
Lifting 举升		18 s
Lowering 降下		14.4 s
Extension 延伸		17.9 s
Retraction 缩回		16.5 s
Crowd 上倾翻		5.1 s
Dump 下倾翻		4 s
Engine 发动机		
Engine brand 发动机品牌		Yuchai 玉柴 (可选品牌)
Engine norm 发动机标准		National II 国II
Max. fuel sulphur content 最大燃油含硫量		5000 ppm
Engine model 发动机型号		YCD4J22T-125
Number of cylinders / Capacity of cylinders 气缸数、气缸容量		4 - 4400 cm ³
I.C. Engine power rating - Power 发动机额定功率-功率		122 Hp / 91 kW
Max. torque / Engine rotation 最大扭矩/发动机转速		400 Nm @ 1400 rpm
Drawbar pull (Laden) 拉杆牵引力 (满载)		10000 daN
Transmission 传动装置		
Transmission type 变速器类型		Torque converter 变矩器 (可选静液压)
Number of gears (forward / reverse) 档位数 (前进/后退)		4 / 4
Max. travel speed 最大行驶速度		40 km/h
Parking brake 驻车制动器		Automatic air-cut brake 断气刹(可选湿式制动)
Service brake 行车制动器		immersed multi-discs braking on front & rear axles
Hydraulics 液压系统		
Hydraulic pump type 液压泵类型		Gear pump 变速箱 (可选柱塞泵)
Hydraulic flow / Pressure 液压泵流量/压力		150 l/min
Tank capacities 油箱容量		
Engine oil 发动机油		5.5L
Hydraulic oil 液压油		70L
Fuel tank 燃油箱		95L
Noise and vibration 噪音和振动		
Noise at driving position (LpA) 驾驶位置噪音		82 dB
Noise to environment (LwA) 环境噪音		105 dB
Vibration on hands / arms 手部/手臂振动		< 2.50 m/s ²
Miscellaneous 其他		
Steering wheels (front / rear) 转向轮		2 / 2
Drive wheels (front / rear) 行走轮		2 / 2
Safety cab homologation 驾驶室安全标准		FOPS level 2 cab

请向操作员说明或告知振动可能造成的危险
 在平整和铺设好的地面上，以适当的驾驶方式在恶劣环境条件下的采掘作业中使用

Bitte unterweisen bzw. informieren Sie den Bediener über mögliche Gefahren durch Vibrationen.
 auf ebenem und befestigten Untergrund bei entsprechender Fahrweise Einsatz in der Gewinnung unter harten Umweltbedingungen.

TELEHANDLER T5010

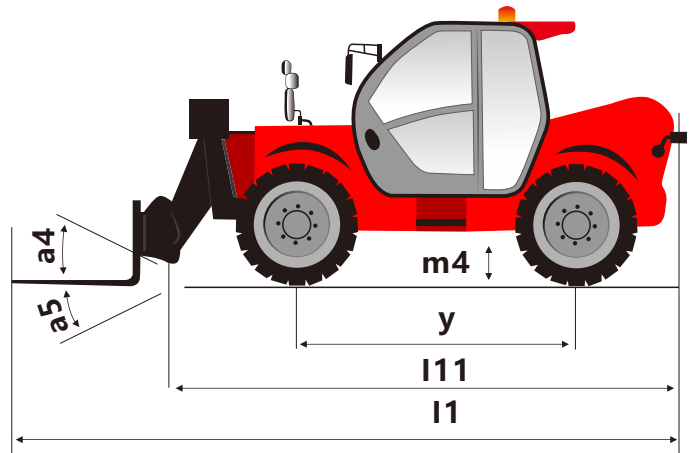
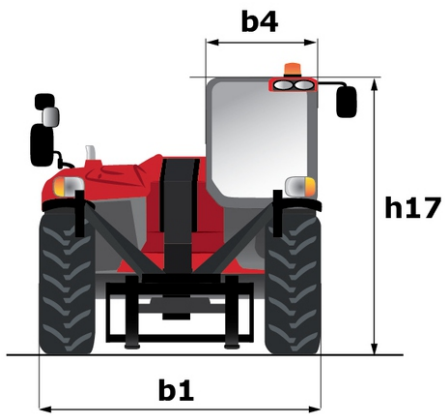

Machine on tyres with forks - with levelling device Metric

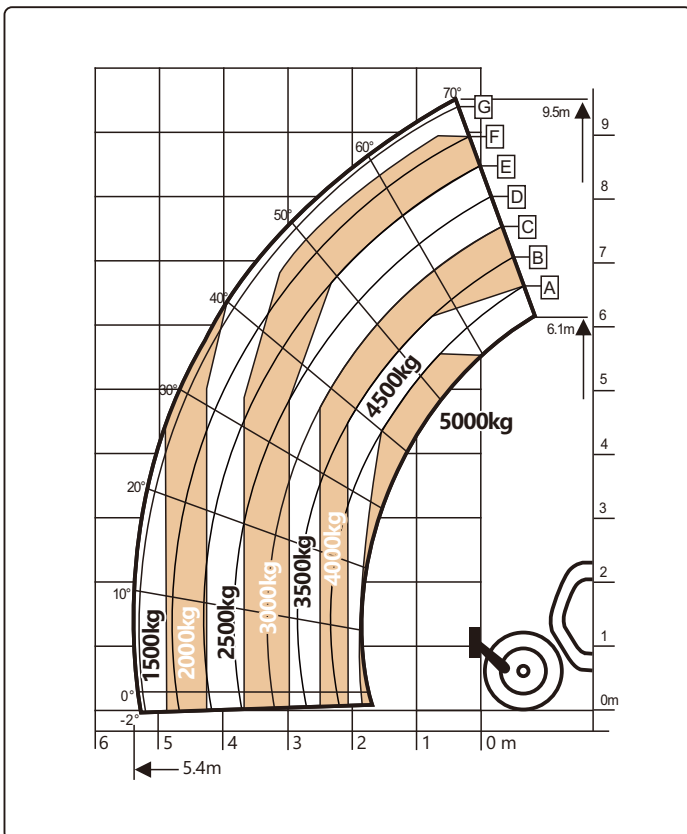

Machine on lowered stabilisers with forks Metric

