

SELF LOADING CONCRETE MIXER TRUCK 自上料搅拌车

HK3.0

Miniature Bodywork
Flexible Operation

微型车身 灵活的操作



型号 Model

HK3.0

整机重量 Overall weight

6800Kg

最大搅拌量 Max mixing capacity

3.0m³

速度 Speed

36.5km/h

罐体可270°旋转三面无死角卸料 270°discharges

移动式自上料混凝土搅拌车是由汉科智能自主研发并已申请国家专利的最新产品。该产品可替代发电机组、装载机、搅拌机、罐车以及6名以上工作人员，是新一代建筑行业上的领先产品。

HANK Automatic Feeding Mixer is the latest product which developed and applied for National patent by Hank Intelligent Equipment Co.,Ltd.This Mixer replace generators, loaders, mixers and even more than six staffs, it is a new generation leading products of Industry construction.The drum can be rotated at 270 degrees with no dead angles .

产品特点 Features

1. 领先设计，自动上料搅拌系统。
 2. 操作简单方便。
 3. 高效率产出，省时省力，节约成本。
 4. 搅拌罐车与装载机、运输车三合一完美结合。
 5. 270度带旋转搅拌罐卸料
1. Leading design, automatic feeding mixing system.
 2. Easy to operate.
 3. Efficient output, saving time , effort and cost.
 4. Mixing tanker and loader, the transport truck is a perfect combination into the whole.
 5. Rotated at 270 degrees mixing and discharge.

Specification 技术参数

型号 MODEL	HK3.0
型式性能 TYPE	一体底盘移动式、自装卸料、搅拌、运送 Integral frame chassis movable, self loading, mixing, transporting
生产功能 PRODUCTIVITY	批次≤15分钟, 每小时4批 (12方) BATCH≤15MINS, 4BATCHS/HOUR
驱动 DRIVE	4 x4
转向 STEERING	后轮转向 Rear wheels steering
发动机 ENGINE	玉柴4缸2200转 / 分钟, 85KW 中冷增压 YUCHAI ENGINE:FOUR-CYLINDER 2200RPM,85KW
行走速度 SPEED	高速36.5公里 / 时 低速6.5公里 / 时 HIGH SPEED:36.5km/h; LOW SPEED :6.5km/h
档位 GEAR NUMBER	前进挡3个, 倒挡3个 Three forwards, three backwards
轮胎 TIRE	16/70-20 (钢丝轮胎) (Steel wire tyre)
搅拌罐 DRUM	几何容积4.2m ³ , 最佳搅拌2.6-3m ³ Geometric volume 6.8 cubic meters, the best stirring 2.6-3 cubic meters
搅拌罐270度卸料 mixing drum	270° discharges 罐体水平旋转达到270度, 车辆周围卸料无死角. The tank rotates horizontally to 270degrees. There is no dead Angle for discharging around the vehicle
铲斗 SHOVEL 容量	0.35m ³
铲斗放料开关 Bucket discharge switch	液压闸门, 电控 Hydraulic gate, electric control
操纵杆 OPERATION HANDLE	电控按钮四向先导手柄 ELECTRIC CONTROL BUTTON FOUR-WAY PILOT HANDLE
供水系统 WATER SUPPLY	上水: 液压驱动自吸式水泵 HYDRAULIC DRIVING SELF-PRIMIING PUMPS.
水箱容积 Water tank capacity	370L
柴油箱容积 Diesel tank capacity	180L
质量 whole weight	整备质量: 6800KG COMPLETE VEHICLE MAX WEIGHT 6800kg

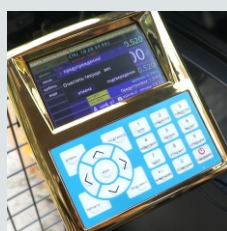
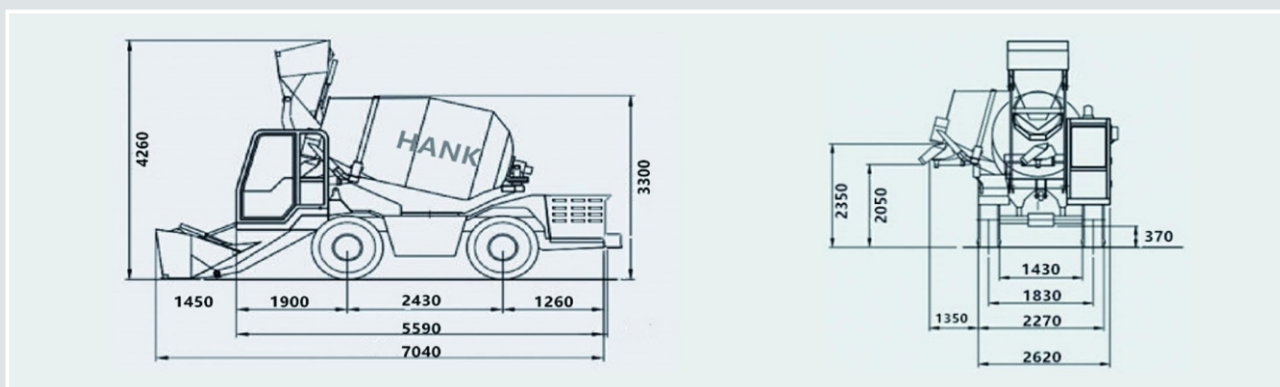

电子计量系统:
自动计量装卸铲斗内物料重量

Electronic metering system:
Automatic weighing material of bucket in loading and discharging



可调方向盘:
可以根据每个人的驾驶习惯自由调节角度

Adjustable steering wheel:
The Angle can be adjusted freely according to each person's driving habits